



POWERING INNOVATION THAT DRIVES HUMAN ADVANCEMENT

© 2025 ANSYS, Inc. or its affiliated companies  
Unauthorized use, distribution, or duplication is prohibited.

# Getting Started with Icepak® - Scripting Example



ANSYS, Inc.  
Southpointe  
2600 Ansys Drive  
Canonsburg, PA 15317  
[ansysinfo@ansys.com](mailto:ansysinfo@ansys.com)  
<https://www.ansys.com>  
(T) 724-746-3304  
(F) 724-514-9494

Release 2025 R2  
July 2025

ANSYS, Inc. and  
ANSYS Europe,  
Ltd. are UL  
registered ISO  
9001:2015 com-  
panies.

## Copyright and Trademark Information

© 1986-2025 ANSYS, Inc. Unauthorized use, distribution or duplication is prohibited.

ANSYS, Ansys Workbench, AUTODYN, CFX, FLUENT and any and all ANSYS, Inc. brand, product, service and feature names, logos and slogans are registered trademarks or trademarks of ANSYS, Inc. or its subsidiaries located in the United States or other countries. Icem CFD is a trademark used by ANSYS, Inc. under license. All other brand, product, service and feature names or trademarks are the property of their respective owners. FLEXIm and FLEXnet are trademarks of Flexera Software LLC.

## Disclaimer Notice

THIS ANSYS SOFTWARE PRODUCT AND PROGRAM DOCUMENTATION INCLUDE TRADE SECRETS AND ARE CONFIDENTIAL AND PROPRIETARY PRODUCTS OF ANSYS, INC., ITS SUBSIDIARIES, OR LICENSORS. The software products and documentation are furnished by ANSYS, Inc., its subsidiaries, or affiliates under a software license agreement that contains provisions concerning non-disclosure, copying, length and nature of use, compliance with exporting laws, warranties, disclaimers, limitations of liability, and remedies, and other provisions. The software products and documentation may be used, disclosed, transferred, or copied only in accordance with the terms and conditions of that software license agreement.

ANSYS, Inc. and ANSYS Europe, Ltd. are UL registered ISO 9001: 2015 companies.

## U.S. Government Rights

For U.S. Government users, except as specifically granted by the ANSYS, Inc. software license agreement, the use, duplication, or disclosure by the United States Government is subject to restrictions stated in the ANSYS, Inc. software license agreement and FAR 12.212 (for non-DOD licenses).

## Third-Party Software

See the legal information in the product help files for the complete Legal Notice for Ansys proprietary software and third-party software. If you are unable to access the Legal Notice, please contact ANSYS, Inc.

## Conventions Used in this Guide

Please take a moment to review how instructions and other useful information are presented in this documentation.

- Procedures are presented as numbered lists. A single bullet indicates that the procedure has only one step.
- Bold type is used for the following:
  - Keyboard entries that should be typed in their entirety exactly as shown. For example, “**copy file1**” means you must type the word **copy**, then type a space, and then type **file1**.
  - On-screen prompts and messages, names of options and text boxes, and menu commands. Menu commands are often separated by greater than signs (>). For example, “click **HFSS > Excitations > Assign > Wave Port.**”
  - Labeled keys on the computer keyboard. For example, “Press **Enter**” means to press the key labeled **Enter**.
- Italic type is used for the following:
  - Emphasis.
  - The titles of publications.
  - Keyboard entries when a name or a variable must be typed in place of the words in italics. For example, “**copy filename**” means you must type the word **copy**, then type a space, and then type the name of the file.
- The plus sign (+) is used between keyboard keys to indicate that you should press the keys at the same time. For example, “Press Shift+F1” means to press the **Shift** key and, while holding it down, press the **F1** key also. You should always depress the modifier key or keys first (for example, Shift, Ctrl, Alt, or Ctrl+Shift), continue to hold it/them down, and then press the last key in the instruction.

**Accessing Commands:** *Ribbons*, *menu bars*, and *shortcut menus* are three methods that can be used to see what commands are available in the application.

- The *Ribbon* occupies the rectangular area at the top of the application window and contains multiple tabs. Each tab has relevant commands that are organized, grouped, and labeled. An example of a typical user interaction is as follows:

"Click **Draw > Line**"



This instruction means that you should click the **Line** command on the **Draw** ribbon tab. An image of the command icon, or a partial view of the ribbon, is often included with the instruction.

- The *menu bar* (located above the ribbon) is a group of the main commands of an application arranged by category such File, Edit, View, Project, etc. An example of a typical user interaction is as follows:

"On the **File** menu, click the **Open Examples** command" means you can click the **File** menu and then click **Open Examples** to launch the dialog box.

- Another alternative is to use the *shortcut menu* that appears when you click the right-mouse button. An example of a typical user interaction is as follows:

"Right-click and select **Assign Excitation> Wave Port**" means when you click the right-mouse button with an object face selected, you can execute the excitation commands from the shortcut menu (and the corresponding sub-menus).

### Getting Help: Ansys Technical Support

For information about Ansys Technical Support, go to the Ansys corporate Support website, <http://www.ansys.com/Support>. You can also contact your Ansys account manager in order to obtain this information.

All Ansys software files are ASCII text and can be sent conveniently by e-mail. When reporting difficulties, it is extremely helpful to include very specific information about what steps were taken or what stages the simulation reached, including software files as applicable. This allows more rapid and effective debugging.

### Help Menu

To access help from the Help menu, click **Help** and select from the menu:

- **[product name] Help** - opens the contents of the help. This help includes the help for the product and its *Getting Started Guides*.
- **[product name] Scripting Help** - opens the contents of the *Scripting Guide*.
- **[product name] Getting Started Guides** - opens a topic that contains links to Getting Started Guides in the help system.

### Context-Sensitive Help

To access help from the user interface, press **F1**. The help specific to the active product (design type) opens.

You can press **F1** while the cursor is pointing at a menu command or while a particular dialog box or dialog box tab is open. In this case, the help page associated with the command or open dialog box is displayed automatically.

# Table of Contents

---

<b>Table of Contents</b> .....	<b>Contents-1</b>
<b>1 - Introduction</b> .....	<b>1-1</b>
<b>2 - Set Up the Project and Analyze the Model</b> .....	<b>2-1</b>
Launch the Ansys Electronics Desktop .....	2-1
Set 3D UI Options .....	2-1
Open the Project .....	2-2
Analyze the Model .....	2-4
<b>3 - Create the Script</b> .....	<b>3-1</b>
Begin Recording the Script .....	3-1
Create a Plane .....	3-1
Plot Temperature on the Plane .....	3-3
Save an Image .....	3-4
Stop Recording the Script .....	3-5
<b>4 - Edit the Script</b> .....	<b>4-1</b>
<b>5 - Run the Script</b> .....	<b>5-1</b>
Additional Scripting .....	5-2



# 1 - Introduction

This document is intended as supplementary material to Icepak for beginners and advanced users. It includes instructions to record, edit, and run a script that generates post-processing objects.

This chapter contains the following topic:

- Sample Project - The Graphics Card

## Sample Project - The Graphics Card

In this project, you will solve the graphics card model and use the Electronics Desktop automation features to record a script, customize it, and use it to automatically create additional cut planes.

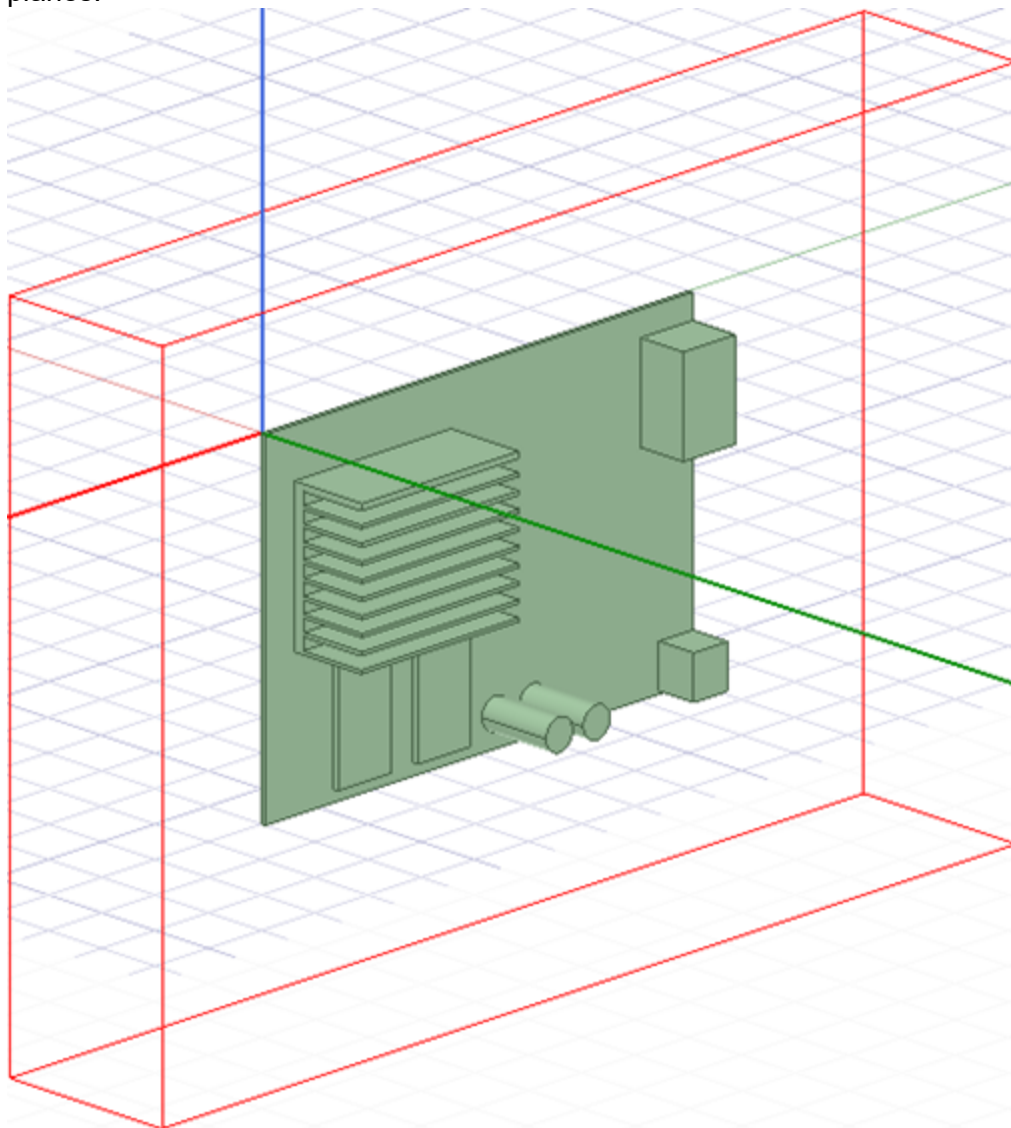

**Figure 1-1: Graphics Card**

## 2 - Set Up the Project and Analyze the Model

This chapter contains the following topics:

- [Launch the Ansys Electronics Desktop](#)
- [Analyze the Model](#)

### Launch the Ansys Electronics Desktop

A shortcut of the Ansys Electronics Desktop application appears on your desktop once the application is installed.

### Set 3D UI Options

Ensure that the new view orientation scheme introduced in release 2024 R1 is not being used, since the instructions and images in this guide are based on the legacy orientation scheme.

1. From the menu bar, click **View > Options**.

The *3D UI Options* dialog box appears.

2. Ensure that **Enable Legacy View Orientation** is enabled:

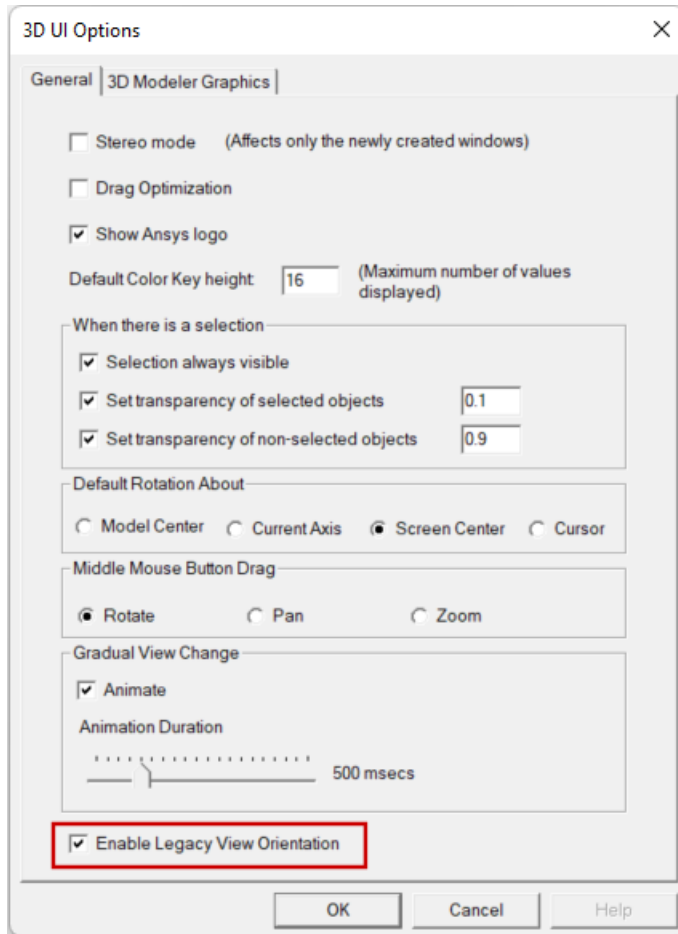

3. Click **OK**.

## Open the Project

1. On the **Desktop** ribbon tab, click  **Open Examples**. Then:
  - a. In the *Open* dialog box that appears, double-click the **Icepak** folder.
  - b. Select the file **Graphics\_Card.aedt** and click **Open**.
2. The model is displayed in the **3D Modeler** window.

**Note:** You can hide the grid by selecting **View > Grid Settings** and then selecting **Hide** in the **Grid Spacing** dialog box. Also, from the **View > Coordinate Systems** menu, you can hide the large coordinate triad and display a smaller coordinate triad in the bottom of the **3D Modeler** window.

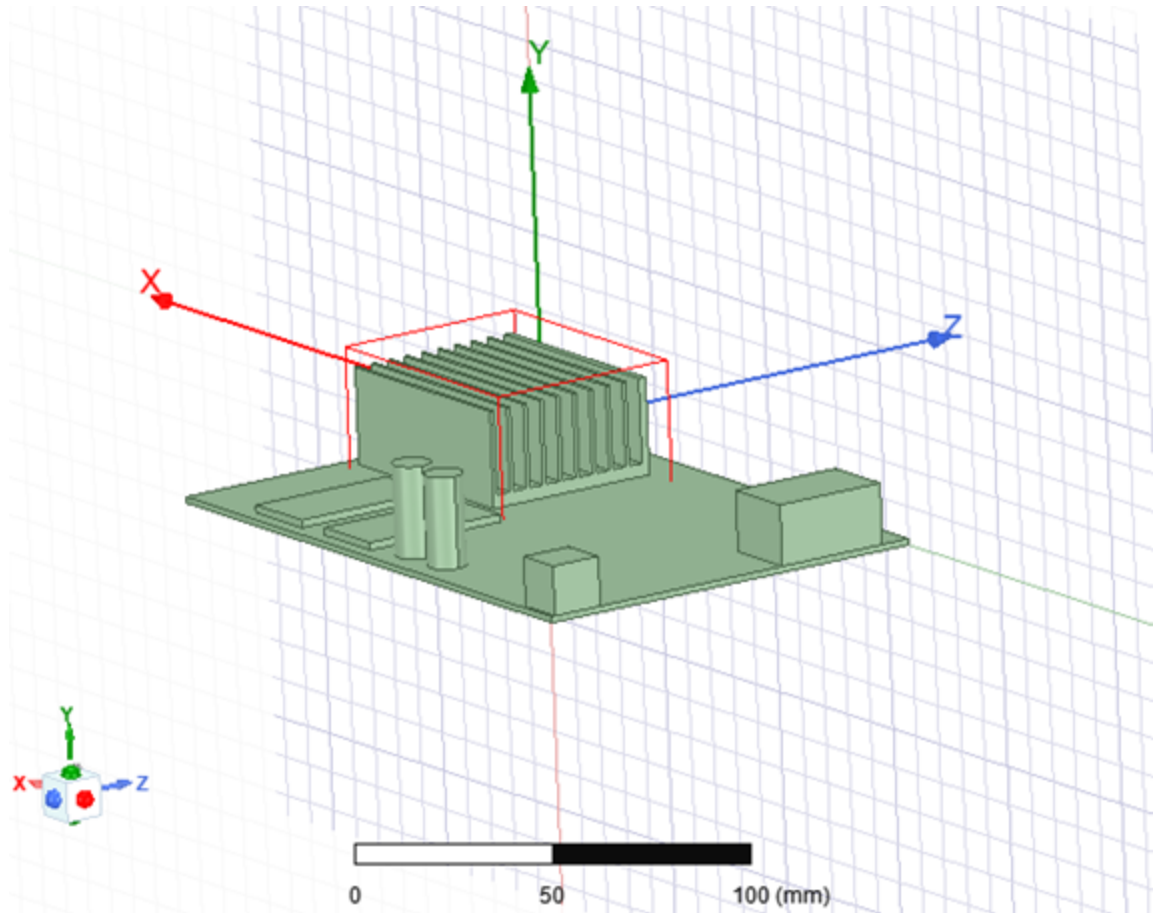
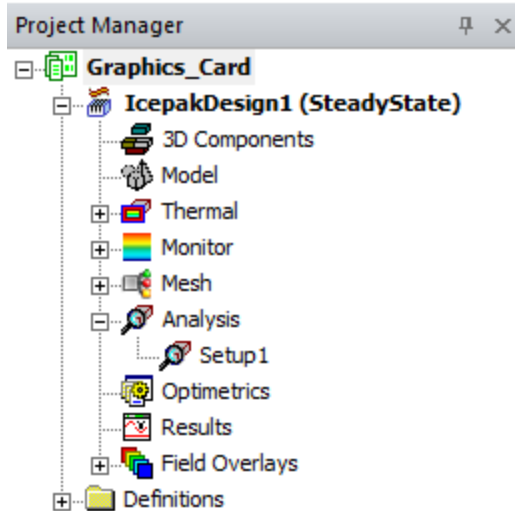

**Figure 2-1: Graphics Card model in the 3D Modeler window**

3. From the **File** menu, select **Save As**, and save the project in the desired working directory.

## Analyze the Model

1. In the **Project Manager**, expand **Analysis**.



2. Under **Analysis**, right-click **Setup1** and select **Analyze** to run the simulation.
3. Right-click on the solution setup (*Setup1*) and select **Residual** to open the **Solutions** dialog box.
4. View the residuals update as the simulation runs.

**Note:** When the simulation is complete, a message is displayed in the **Message Manager** indicating normal completion.

## 3 - Create the Script

Use the Electronics Desktop's automation features to record a script of creating a plane and plotting a field overlay.

### Begin Recording the Script

1. On the **View** ribbon, select **Dimetric** from the **Orient** drop-down list.
2. On the **Automation** ribbon, click **Record Script**.

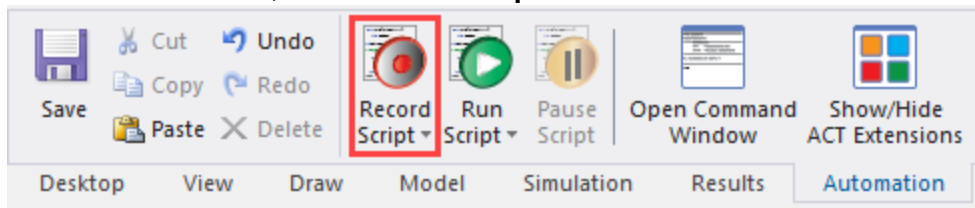

3. In the **Save As** dialog box, browse to your working directory if necessary, enter a **File name**, and click **Save**.

### Create a Plane

1. In the History Tree, expand **Model > Solids > air**.
2. Right-click **Region** and select **View > Show in Active View** to display the computational domain in the **3D Modeler**.
3. In the **3D Modeler** window, hover the cursor over the center of the max X side of the board geometry as shown below.

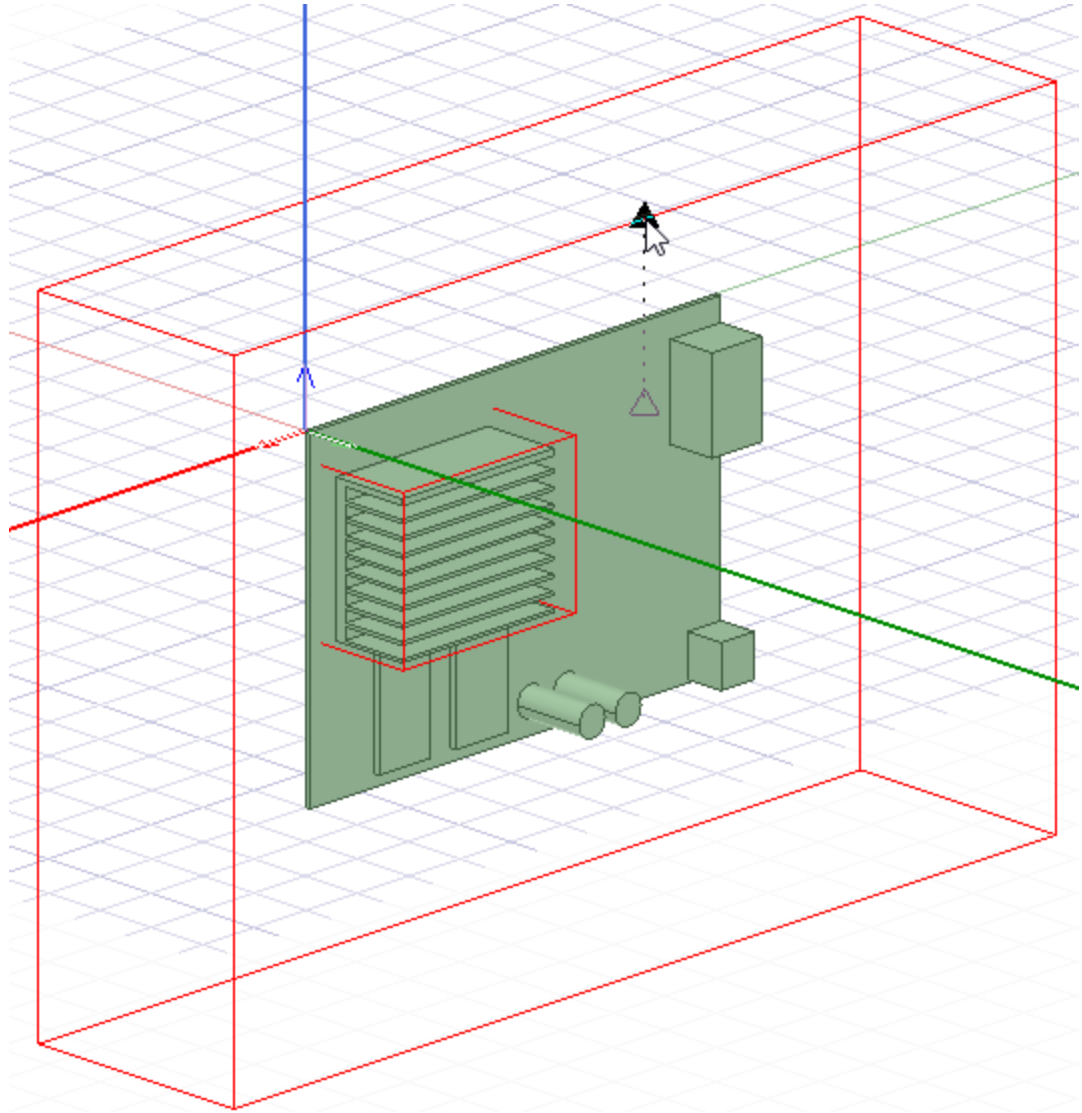

4. While the triangle icon is displayed, click to set the location of the plane.
5. While pressing and holding X, move the cursor, and then click to create the plane.

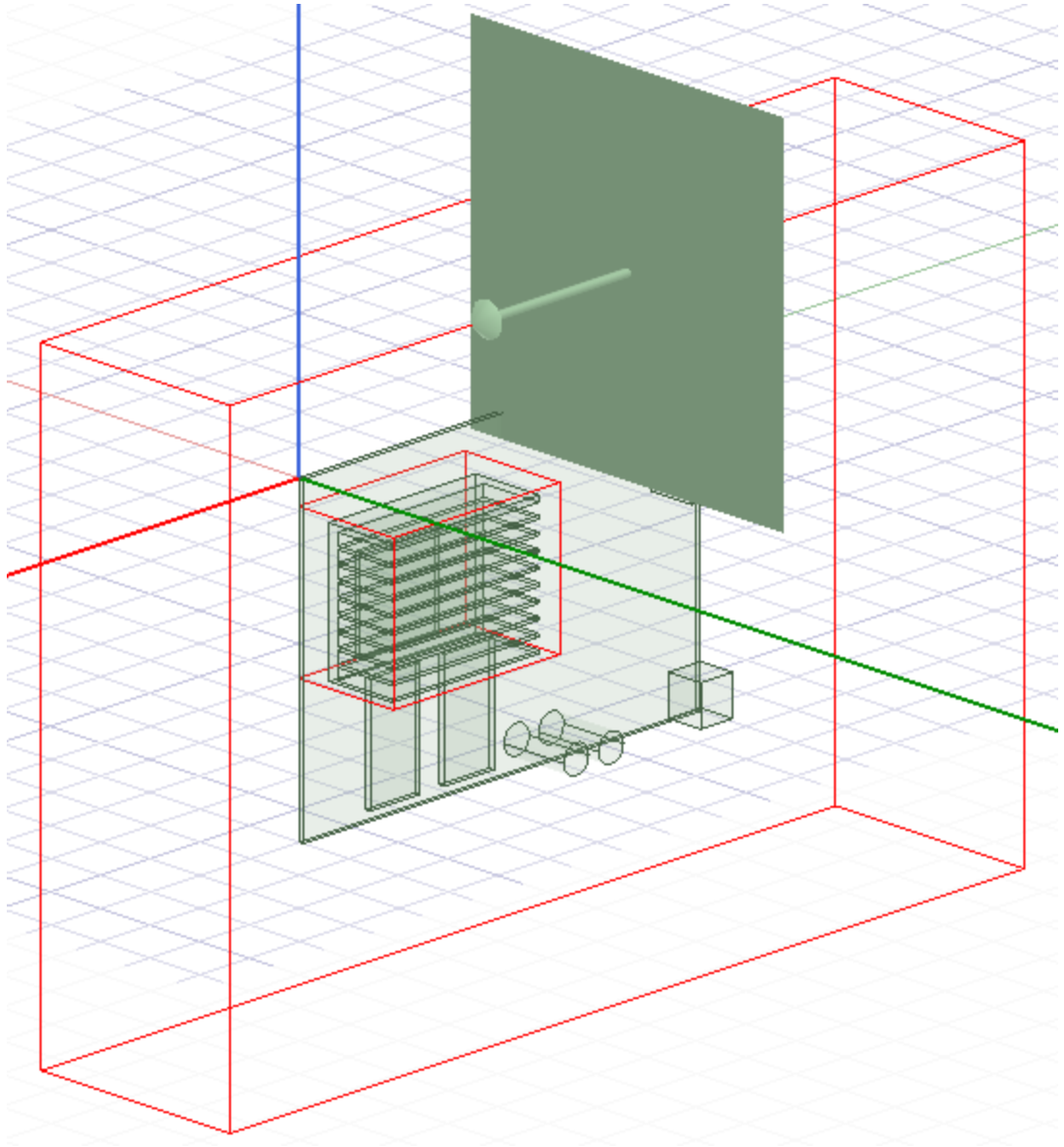

## Plot Temperature on the Plane

1. In the history tree, expand **Planes** and select **Plane2**.
2. In the **3D Modeler** window, right-click and select **Plot Fields > Temperature > Temperature**.

3. In the **Create Field Plot** dialog box, retain the default settings and click **Done**.

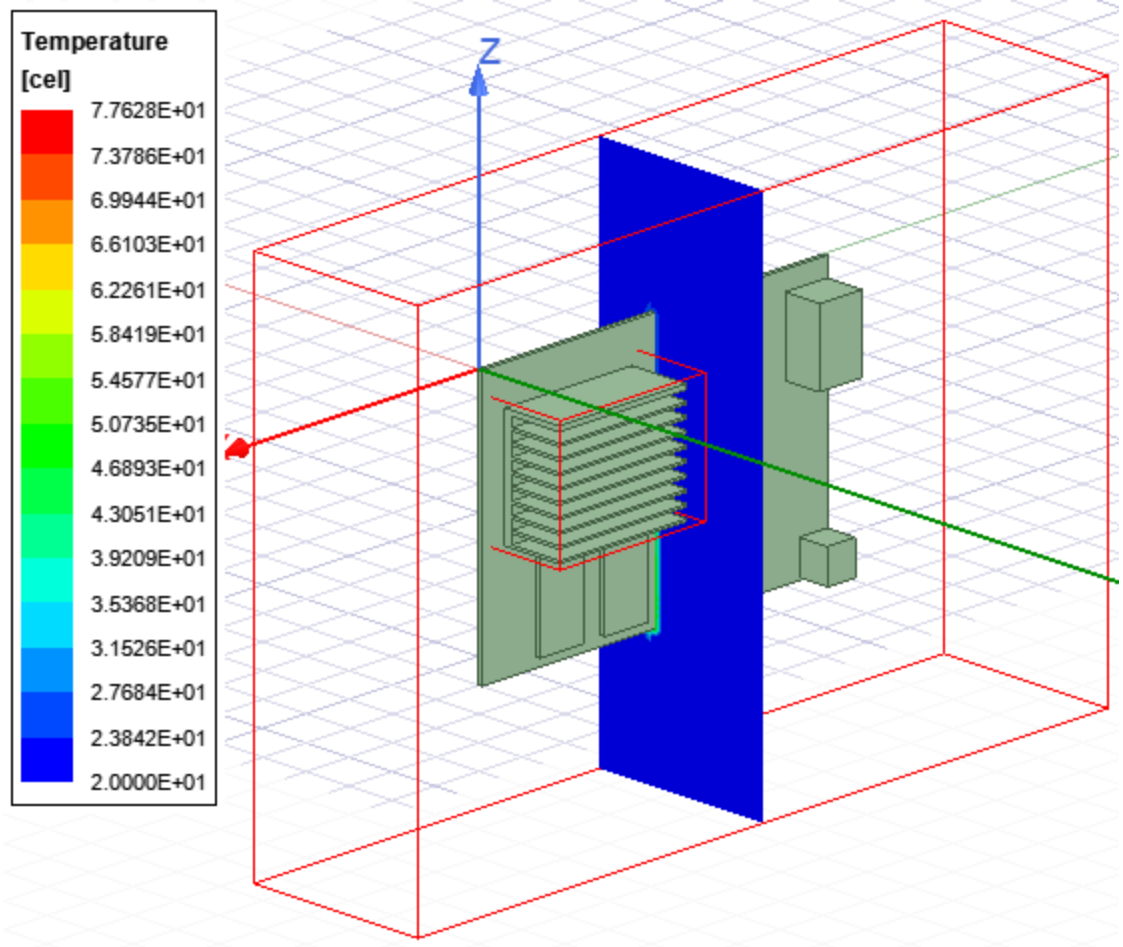

## Save an Image

**Note:**

The orientation of the model in the 3D Modeler window appears as is in the saved image.

1. From the **Modeler** menu, select **Export**.
2. In the **Export File** dialog box, ensure **JPEG Files (\*.jpg)** in the **Save as type** drop-down list.
3. Browse to your working directory if necessary, enter a **File name**, and click **Save**.

## Stop Recording the Script

1. Click the **Automation** ribbon.
2. Click **Stop Recording**.



## 4 - Edit the Script

Use a plain text editor to customize the script to create multiple plane cuts in the computational domain.

1. Navigate to your working directory where you previously saved the script.
2. Open the script the with a plain text-editing application.

**Important:**

Python script formatting (e.g., indentation) can cause syntax errors to occur.

3. As shown in the image below, enter the following code into the appropriate location in the script. This initializes the numbering applied to planes and plane cut and defines variables to be used in the script.

```
num = 0

for xpos in range(-240, 80, 40):

    num = num + 1
    plane_name = "plane." + str(num)
    post_name = "NAME:Temperature." + str(num)
    post_name_img = "Temperature." + str(num)

    plane_xpos = str(xpos) + "mm"
```

```
1 # -----
2 # Script Recorded by Ansys Electronics Desktop Version 2022.1.0
3 # 12:30:36 Oct 01, 2021
4 # -----
5 import ScriptEnv
6 ScriptEnv.Initialize("Ansoft.ElectronicsDesktop")
7 oDesktop.RestoreWindow()
8 oProject = oDesktop.SetActiveProject("Graphics_Card")
9 oDesign = oProject.SetActiveDesign("IcepakDesign1")
10 oEditor = oDesign.SetActiveEditor("3D Modeler")
11
12 num = 0
13
14 for xpos in range(-240,80,40):
15
16     num = num + 1
17     plane_name = "plane." + str(num)
18     post_name = "NAME:Temperature." + str(num)
19     post_name_img = "Temperature." + str(num)
20
21     plane_xpos = str(xpos) + "mm"
22
23 oEditor.CreateCutplane(
24     [
25         "NAME:PlaneParameters",
```

**Note:**

In the image above, the numbers in line 14 define the X position range (-240 to 80) and the interval (40) at which to create the plane cut and save the image. To determine the range of a Region (computational domain), use the **Measure > Position** tool from the **Modeler** menu.

4. As shown in the following image in the *CreateCutplane* function, enter the variable names for *PlaneBaseX* and *Name*.

```
23  oEditor.CreateCutplane (  
24      [  
25          "NAME:PlaneParameters",  
26          "PlaneBaseX:="      , plane_xpos,  
27          "PlaneBaseY:="      , "52mm",  
28          "PlaneBaseZ:="      , "55mm",  
29          "PlaneNormalX:="    , "160mm",  
30          "PlaneNormalY:="    , "0mm",  
31          "PlaneNormalZ:="    , "0mm"  
32      ],  
33      [  
34          "NAME:Attributes",  
35          "Name:="            , plane_name,  
36          "Color:="          , "(143 175 143)"  
37      ])  
    )
```

5. As shown in the following image in the *CreateFieldPlot* function, replace "NameTemperature2" with the variable *post\_name* and "Plane1" with *plane\_name*.

```

39  oModule.CreateFieldPlot (
40  [
41  post_name,
42  "SolutionName:=" , "Setup1 : SteadyState",
43  "UserSpecifyName:=" , 0,
44  "UserSpecifyFolder:=" , 0,
45  "QuantityName:=" , "Temperature",
46  "PlotFolder:=" , "Temperature",
47  "StreamlinePlot:=" , False,
48  "AdjacentSidePlot:=" , False,
49  "FullModelPlot:=" , False,
50  "IntrinsicVar:=" , "",
51  "PlotGeomInfo:=" , [1,"Surface","CutPlane",1,plane_name],
52  "FilterBoxes:=" , [0],
53  [
54  "NAME:PlotOnSurfaceSettings",
55  "Filled:=" , False,
56  "IsoValType:=" , "Fringe",
57  "AddGrid:=" , False,
58  "MapTransparency:=" , True,
59  "Refinement:=" , 0,
60  "Transparency:=" , 0,
61  "SmoothingLevel:=" , 0,
62  "ShadingType:=" , 0,
63  [
64  "NAME:Arrow3DSpacingSettings",
65  "ArrowUniform:=" , True,
66  "ArrowSpacing:=" , 0,
67  "MinArrowSpacing:=" , 0,
68  "MaxArrowSpacing:=" , 0
69  ],
70  "GridColor:=" , [255,255,255]
71  ],
72  "EnableGaussianSmoothing:=" , False
73  ], "Field")
74

```

6. As shown in the image below in the *ExportModellImageToFile* function, enter the following code into the appropriate location in the script. Also, replace the file path with `file_path` and enter `post_name_img` for *FieldPlotSelections*.

```

path_root = "C:/path_to_folder/"
file_name = "temp_cut_x_" + str(plane_xpos) + ".jpg"
file_path = path_root + file_name

```

```
75 path_root = "C:/path_to_folder/"
76 file_name = "temp_cut_x_" + str(plane_xpos) + ".jpg"
77 file_path = path_root + file_name
78
79 oEditor.ExportModelImageToFile(file_path, 866, 757,
80 [
81     "NAME:SaveImageParams",
82     "ShowAxis:="          , "True",
83     "ShowGrid:="          , "True",
84     "ShowRuler:="         , "True",
85     "ShowRegion:="        , "Default",
86     "Selections:="        , "",
87     "FieldPlotSelections:=" , post_name_img,
88     "Orientation:="       , ""
89 ]
90
```

**Note:**

In the image above, the definition of *path\_root* in line 75 specifies the save location of the exported images. Use forward slashes when you modify this line to specify the path to your working directory.

## 7. Save the script.

**Note:**

A copy of the edited script is included in the Electronics Desktop installation in the following folder:

```
C:\Program Files\AnsysEM\softwareversion\Win64\Help\Icepak\Icepak_createcutplanes.py
```



## 5 - Run the Script

Run the edited script to automatically create the post-processing objects and cut plane images.

1. In the **3D Modeler** window, ensure the model is displayed in an appropriate orientation to display the cut planes in the images that will be exported while the script is running.
2. Navigate to the **Automation** ribbon.
3. Click **Run Script**.

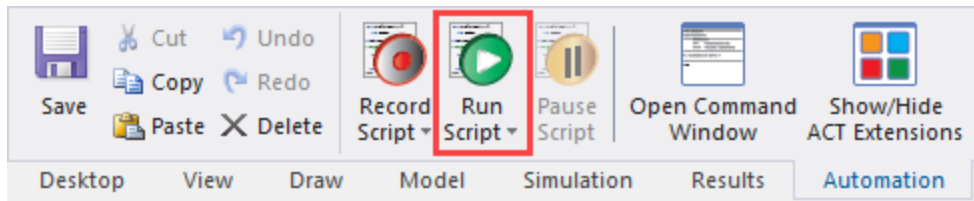

4. In the **Run Script** dialog box, browse to your working directory, select the script, and click **Open** to run it.
5. After the script has finished running, review the cut planes in the **3D Modeler** window. Note the post-processing objects under **Field Overlays** in the **Project Manager** and the planes in the History Tree.

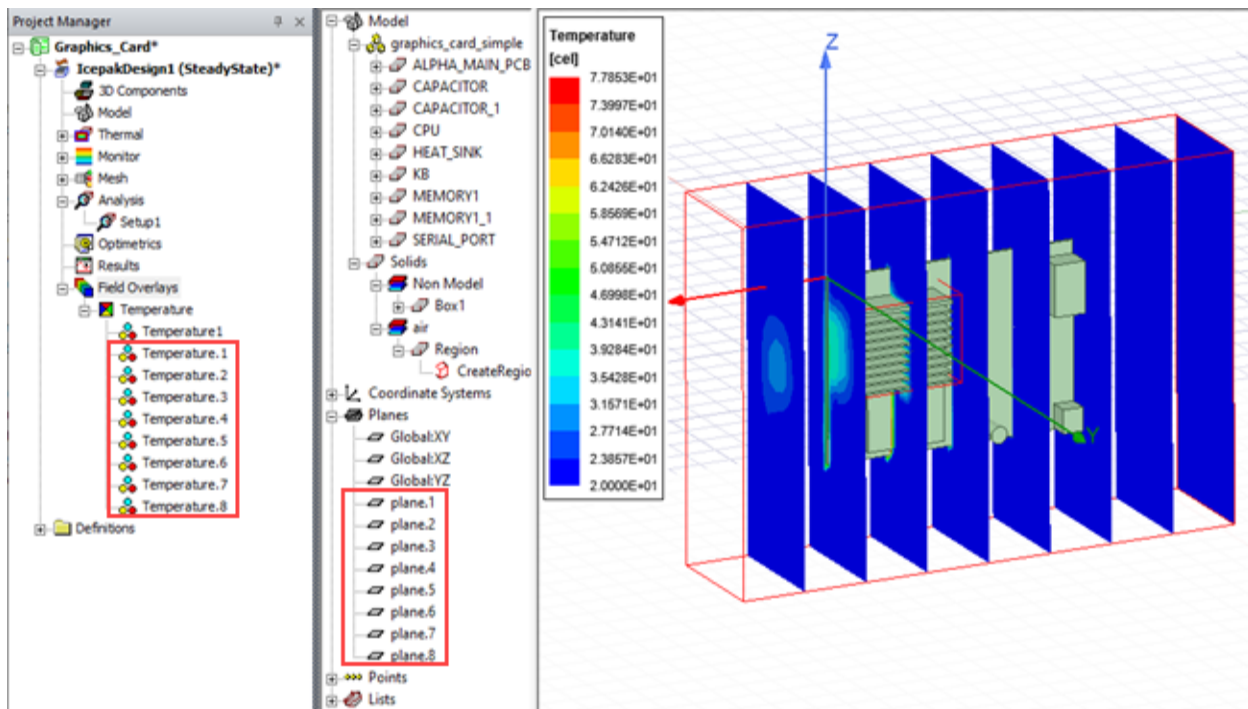

6. Navigate to your working directory and review the images of each cut plane created by the script.

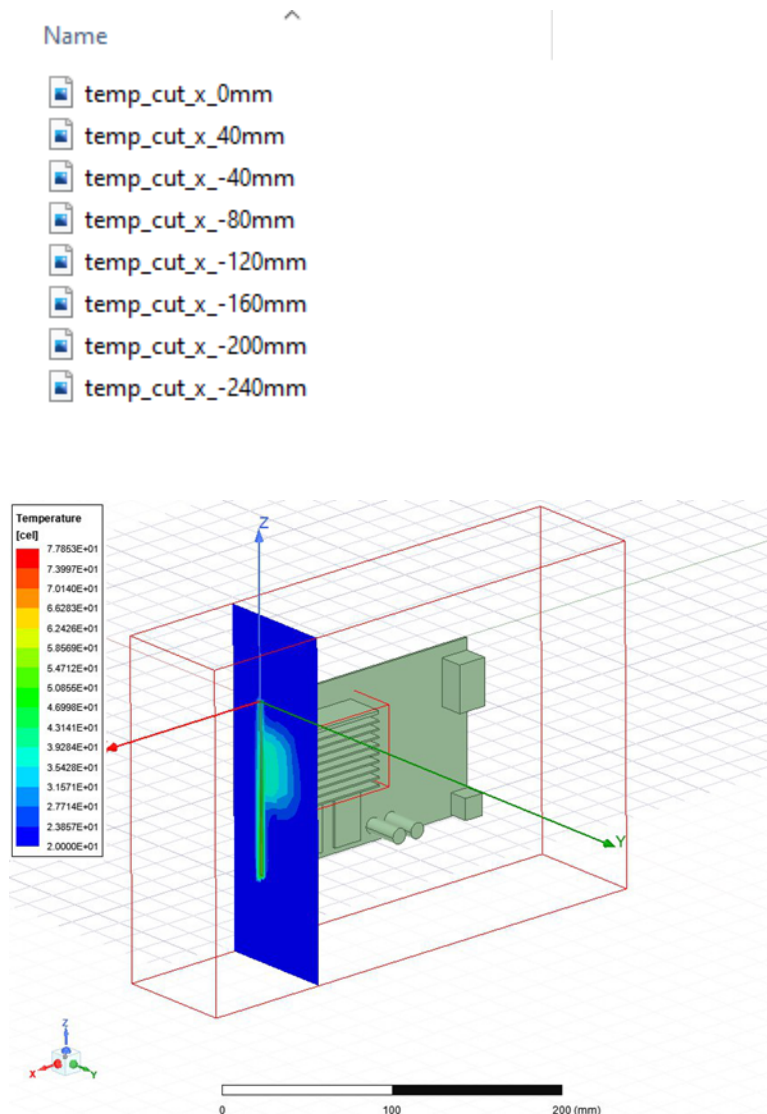

## Additional Scripting

You can make modifications to this script to post-process different results, change the image resolution, or edit the orientation. See the Icepak Scripting Guide for more information regarding scripting commands for Icepak features.